

2  
NEW DETAIL  
ADDENDUM  
#2

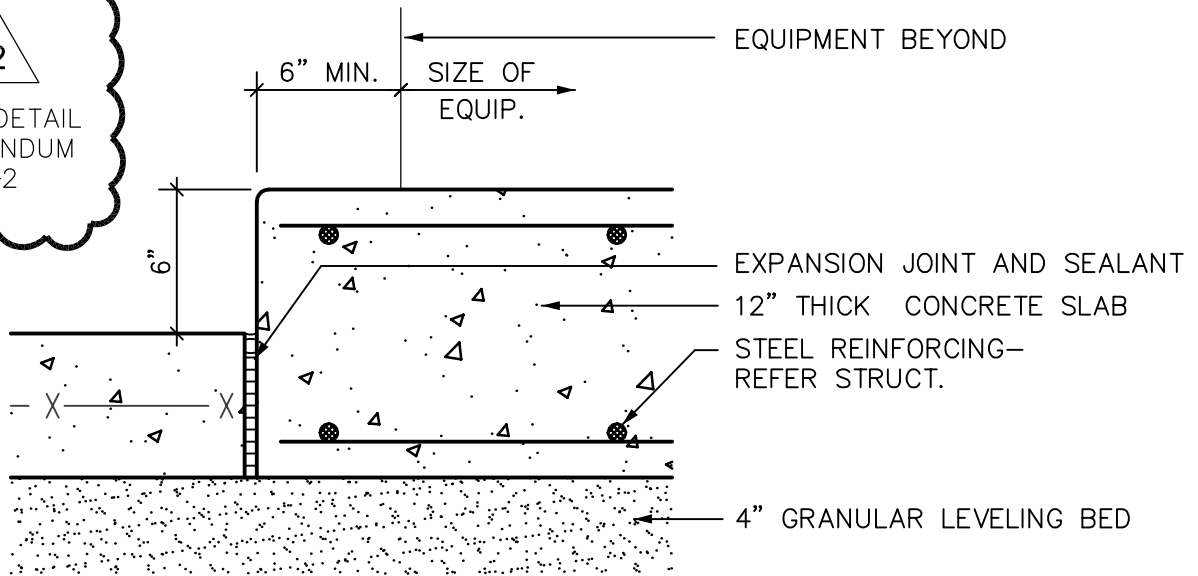

NOTE: REF. MECH. CONTRACTOR FOR SIZE OF EQUIPMENT

**C5**

**EQUIPMENT PAD - INTERIOR**

1 1/2" = 1'-0"

D3.14

© 2008 SCHAEFER JOHNSON COX FREY & ASSOCIATES, P.A.

SCHAEFER JOHNSON COX FREY ARCHITECTURE

Empire Center  
257 N. Broadway  
Wichita, Kansas  
67202-2317  
Ph. 316.684.0171  
Fax. 316.684.8836  
www.sjcf.com  
architecture@sjcf.com

PRJ NO. 2955.00

**NATIONAL CENTER  
FOR AVIATION TRAINING  
JABARA CAMPUS**

WEBB ROAD  
WICHITA, KS 67206

**A63.1**

REV. 07 NOV. 08