

City of Wichita Standard for

Residential Wood Framed Decks

Amendments and Changes to the AWC DCA6-09 Document

“Prescriptive Residential Wood Deck Construction Guide”

For the City of Wichita Deck Standard



C I T Y ■ O F
W I C H I T A

November 01, 2010

Revised 12/22/2011

The City of Wichita has accepted the Design for Code Acceptance document (AWC DCA6-09) for design and construction of residential wood decks. Permission has been granted by the American Wood Council to reference this document as currently published. (Please see **Attachment 1**. of this document.) The AWC DCA6-09 document can be viewed and downloaded at <http://www.awc.org/Publications/DCA/DCA6/DCA6-09.pdf>. The American Wood Council is solely responsible for the content and maintenance of AWC DCA6-09 and for any updates or companion publications.

The Wichita Residential Wood Deck Standard assumes sixteen (16) feet maximum joist and/or beam span, use of pressure treated southern yellow pine for joists, beams and stair stringers, and a maximum height of twelve (12) feet from bearing to the bottom of beams. All drawings used in this standard are solely to illustrate construction requirements and are not drawn to scale.

For construction techniques and situations not addressed in the AWC DCA6-09 or outside of the scope of this Standard, the International Residential Code, as currently adopted by the City of Wichita, shall be considered the controlling document.

PAGE 1 OF AWC DCA6-09

- a. The City of Wichita has adopted the 2006 International Residential Code, as it is currently amended, and all [bracketed text] references applicable sections of the 2006 IRC.

PAGE 2 OF AWC DCA6-09

- a. Amend “Deck Framing Plan.....6” from Contents section to read :
“Deck Framing Plan..(optional).....6”
- b. Amend item # 2 of Minimum Requirements to read:

“2. All lumber shall be identified by the grade mark of, or certificate of inspection issued by, an approved lumber grading or inspection bureau or agency (www.alsc.org). All lumber, other than pressure treated southern yellow pine used for joists, beams, and stair stringers, shall be a naturally durable species (such as Redwood or Western Cedars) or be pressure-treated with an approved process and preservative in accordance with American Wood Protection Association standards (such as but not limited to those shown in Table 1) [R319.1 and R320.1]. All lumber in contact with the ground shall be approved preservative treated wood suitable for ground contact. [R319.1.2]”
- c. Amend item #4 of Minimum Requirements to read:
“4. Throughout this document, ½” diameter bolts and lag screws (or equivalent) are specified for various connections. Edge distance and spacing requirements are based on ½” diameter fasteners. If larger (or smaller) fasteners are specified, edge distance and spacing needs to be adjusted.”

d. Amend item # 10 of Minimum Requirements to read:

“10. This document is not intended to preclude the use of other construction methods or materials not shown herein when designed and sealed by a licensed Kansas professional.”

PAGE 3 OF AWC DCA6-09

- a. Table 1 shall be omitted.
- b. Table 2 shall omit species other than Southern Pine and footnotes “3” and “4”.

PAGE 4 OF AWC DCA6-09

No changes

PAGE 5 OF AWC DCA6-09

- a. Table 3 shall omit species other than Southern Pine and footnotes “2” and “3”.

PAGE 6 OF AWC DCA6-09

- a. Amend “DECK FRAMING PLAN” to read: “DECK FRAMING PLAN optional--not required for permit”.

PAGE 7 OF AWC DCA6-09 [See attachment 4 for optional use of 4 x 4 posts]

Under Post Requirements:

- a. Omit ~~“Cut ends of posts shall be field treated with an approved preservative (such as copper naphthenate) [R402.1.2].”~~

PAGE 8 OF AWC DCA6-09 [See attachment 4 for optional use of 4 x 4 posts]

- a. Amend Figure 8 to include the wording: “Notches in posts MUST NOT be overcut.”
- b. Amend Figure 8 to include the wording: “Counter bores are allowed only in the beam; not in the post.”

Page 9 OF AWC DCA6-09 [See attachment 4 for optional use of 4 x 4 posts]

- a. “ FOOTINGS [R403]” section shall be amended by removing the “4” from “Table 4”. The “12” shall be replaced by “24” inches below the undisturbed ground.... The reference to ~~“(call 811)”~~ shall be omitted.

b. Table 4 shall be replaced by City of Wichita table for footing sizes and reinforcing requirements.

c. Figure 12 shall be replaced by City of Wichita drawing for Typical Footing. With the following: “NOTE: Posts shall not be placed into concrete footings. They shall only be attached by means of approved post base anchors or other method designed and sealed by a Kansas licensed professional. The top of the footing shall extend above finished grade by a minimum of 6 inches.”

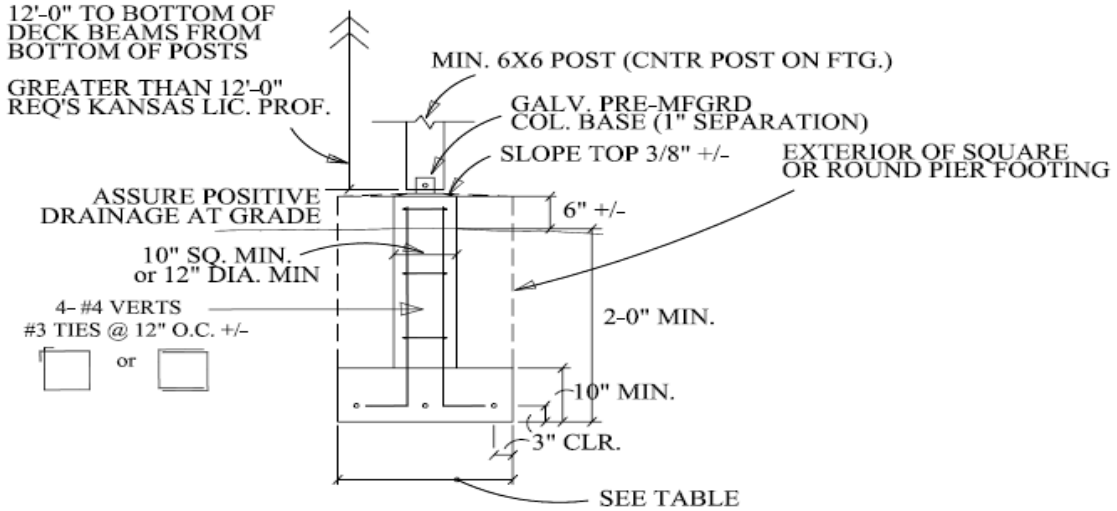

NOTE: FOOTING MAY BE INCORPORATED INTO POURED CONCRETE SLAB WITH A MINIMUM 1" OF SEPARATION BETWEEN BOTTOM OF POST AND SLAB.

TRIBUTARY DECK AREA (SQ. FT.) - SEE ATTACHMT 2	MIN. SQ. FTG. SIZE (FT. - IN.)	ALTERNATE ROUND PIER FTG. SIZE (IN)	REINF. EA. WAY BOT.
16	1-0	12 *	-
24	1-3	16 *	-
48	1-6	18	2 - #4
72	1-9	24	2 - #4
96	2-0	27	2 - #4
120	2-3	30	3 - #4
144	2-6	33	3 - #4

* REINFORCE ROUND PIER AS SHOWN ABOVE

Page 10 OF AWC DCA6-09

- a. Omit reference to IRC Code section [~~R502.2.2~~] and replace with [R502.2.1]
- b. Under **“GENERAL:”** Omit ~~“through Figure 16”~~ and replace with “and 15”.
- c. Under **“SIDING AND FLASHING:”** Omit ~~“with drip edge”~~.

Page 11 OF AWC DCA6-09

- a. Figure 16 shall be omitted.

Page 12 OF AWC DCA6-09

- a. Amend “PROHIBITED LEDGER ATTACHMENTS” to read:

“Attachments to exterior veneers (brick, masonry, stone) and to cantilevered floor overhangs or bay windows are prohibited (see Figures 17 and 18). In such cases the deck shall be free-standing (see FREE-STANDING DECKS) or designed and sealed by a Kansas licensed professional.”

- b. Amend the title of Table 5 as follows:

“Table 5. Fastener Spacing for a Southern Pine, ~~Douglas Fir-Larch, or Hem-Fir~~ Deck Ledger and a 2-inch Nominal Solid-Sawn Spruce-Pine-Fir^{7,9} Band Joist or EWP Rim Board⁶”

Page 13 OF AWC DCA6-09

No changes

Page 14 OF AWC DCA6-09 [See attachment 4 for optional guard specifications]

- a. Amend Figure 22 by changing post height to read: “~~14'-0"~~ 12'-0" maximum.”
- b. “**Guard Requirements**” shall be amended to read as follows:

All decks greater than 30” above grade are required to have a guard [R312.1] meeting the load requirements of [Table R301.5] and the maximum deflection allowance shown in [Table R301.7] - one example is shown in Figure 24. Guards must be mechanically secured to posts with methods other than toe-nails. One method for accomplishing this is shown in the following two (2) illustrations.

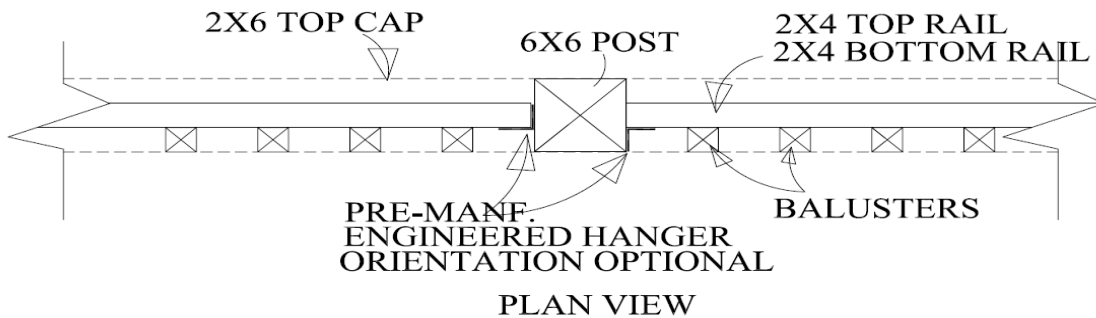

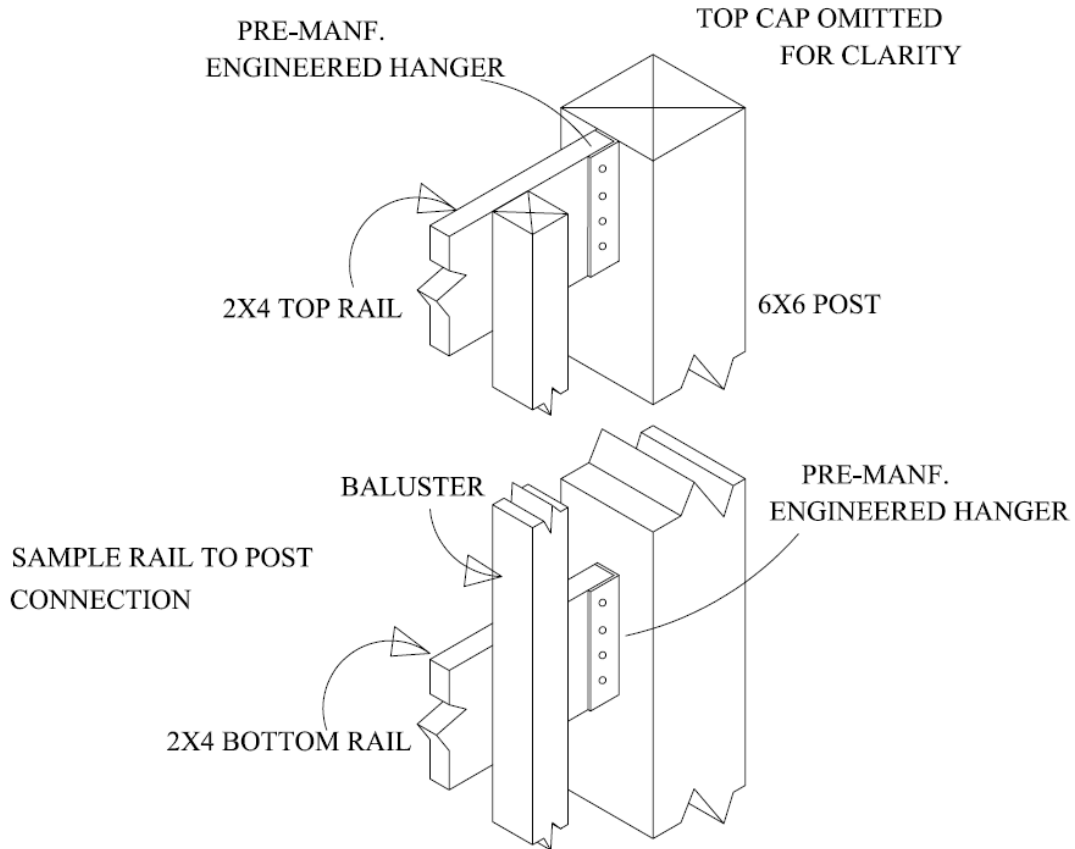

Other methods and materials may be used for guard construction when approved by the authority having jurisdiction.

Page 15 OF AWC DCA6-09

- a. Under “**Diagonal Bracing:**” Omit the following: “Decks attached to the house as shown in Figure 23A do not require diagonal bracing perpendicular to the house.”
- b.
- c. Under “**Deck Supported by Ledger - Attachment to House:**”
 - i. Omit the reference to Figure “16”
 - ii. Omit reference to IRC Code section [R502.2.2] and replace with [R502.2.1]
 - iii. Omit the following: “The lateral load connection required shall be permitted to be in accordance with Figure 23A. Hold down tension devices shall be provided in not less than two locations per deck, and each device shall have an allowable stress design capacity of not less than 1,500 lb [R502.2.2.3]. See the *Commentary* to this document for additional information on applicability of this provision.”
- d. Omit Figure 23A.
- e. Amend Figure 24 as follows: “openings shall not allow the passage of a 4” 4½” diameter sphere”

No changes

- a. Under “STAIR REQUIREMENTS” The following shall be amended:
“For stairs with solid stringers or which are greater than 36” in width, a combination of cut and solid stringers can be used, but shall be placed at a maximum spacing of 18” on center (see revised Figure 29 below).

The following text shall be placed at the end of this section: “Tread materials other than wood products shown in Table 6 shall be installed per manufacturer’s installation requirements or approved by the Authority Having Jurisdiction.

- b. Figure 27 shall be amended as follows:
- i. ~~7³/₄~~ 8” maximum riser; height shall not deviate from one another by more than ³/₈”
 - ii. ~~10~~ 9” minimum tread width
 - iii. riser may be open, but shall not allow the passage of a ~~4~~ 6” diameter sphere
- c. Figure 28 shall have the following omitted:
- i. Above “CUT STRINGER”-- ~~max. span = 6’-0” for other Table 1 species~~
 - ii. Above “SOLID STRINGER”-- ~~max. span = 13’-3” for other Table 1 species~~
- d. Figure 29 shall be amended as follows:
- i. SOLID STRINGER detail revised to show a cut stinger located common to center of tread.

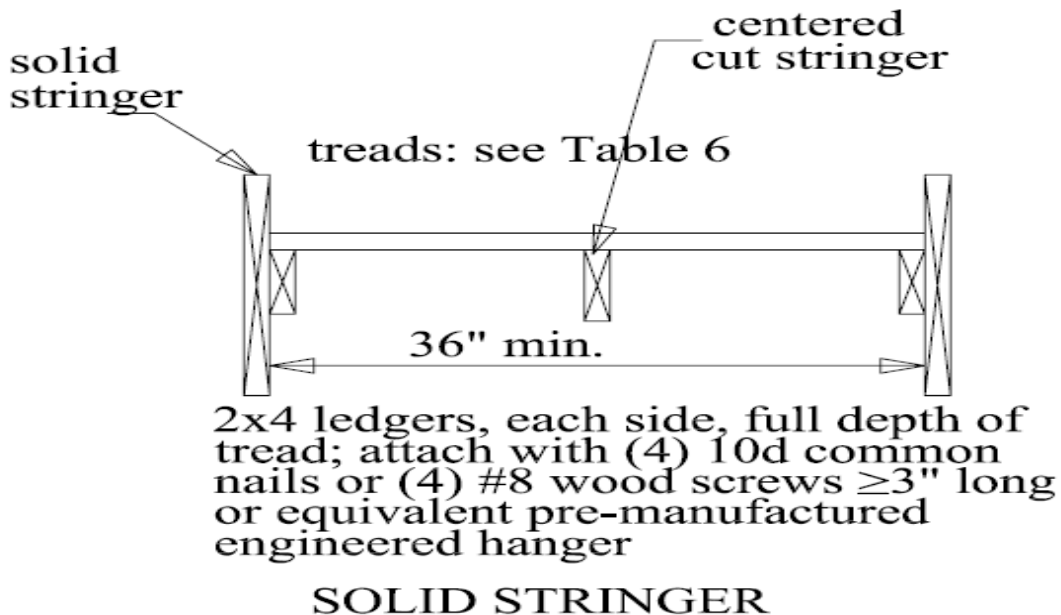

- a. Figure 30 shall be amended as follows:
 - i. The following text shall be added: "Spacing between guard posts to meet the minimum requirements of Tables [R301.5] and [R301.7]; or 6' - 0" maximum."
 - ii. "Openings for required guards on the sides of stair treads shall not allow a sphere of ~~4³/₈"~~ 4¹/₂" to pass through."
- b. Under "**STAIR HANDRAIL REQUIREMENTS**" The following shall be amended:
"All stairs with 4 or more risers shall have a handrail on at least one side (see Figure 32A) [~~R311.7.7~~] [R311.5.6]. The handrail height measured vertically from the sloped plane adjoining the tread nosing shall be not less than ~~34~~ 32 inches and not more than 38 inches (see Figure 30) [~~R311.7.7.4~~] [R311.5.6.1]. ... Type II rails with a perimeter greater than 6-1/4" shall provide a graspable finger recess area on the outboard side ~~both sides~~ of the profile [~~R311.7.7.3~~] [R311.5.6.3]. ... Handrails shall run continuously from a point directly over the lowest riser to a point directly over the highest riser and shall return to the guard at ~~each~~ the top end (see Figure 33). Handrails may be interrupted by guard posts at a turn in the stair [~~R311.7.7.2~~] [R311.5.6.2]."
- c. Figure 32A. shall be amended as follows:
 - i. 32" 34" -38" to nosing of stairs. Typical
- d. Figure 32B. shall be amended as follows:
 - i. [~~R311.7.7.3~~ R311.5.6.1 Type I]
 - ii. [~~R311.7.7.3~~ R311.5.6.1 Type II]

- a. Under "**STAIR FOOTING REQUIREMENTS**" The following shall be amended: ...
All footings shall bear on solid ground and shall be placed at least ~~12~~ 24 inches below the undisturbed ground surface ~~or below the frost line, whichever is deeper~~ (see Figure 34). Posts supporting stair stringers at grade or used as guard posts may be placed into the concrete pier with a minimum section and footing thickness equal to or greater than shown in Figure 34.
- b. Figure 33 shall be amended as follows:
 - i. handrail height 32" 34" - 38" from nosing of step
 - ii. handrail shall return at ~~each~~ top end
- c. Figure 34 shall be amended as follows:
 - i. ~~12" 24"~~ 24" minimum frost depth
- d. Under "**FRAMING AT CHIMNEY OR BAY WINDOW**" The following shall be amended: ...
Headers with a span length greater than 6'-0" require a ~~plan submission~~ design and seal by a licensed Kansas professional.

No changes

Attachment 1.



**Prescriptive Residential Wood
Deck Construction Guide**
Based on the *2009 International Residential Code*

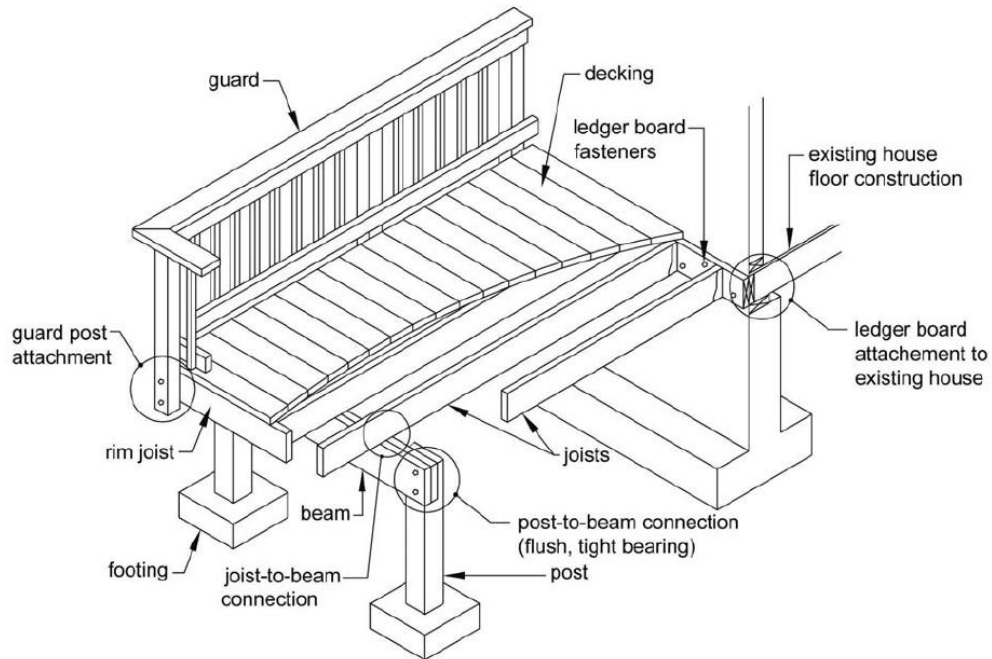

This document is subject to updates and revisions. To ensure that you always have the latest version of the document, follow this link to download a free copy of the most current *Prescriptive Residential Wood Deck Construction Guide*: <http://www.awc.org/Publications/DCA/DCA6/DCA6-09.pdf>.

For information about copyright permission and hyperlinks, follow this link: <http://www.awc.org/CopyrightDisclaimer.html>.

Additional questions: <http://www.awc.org/HelpOutreach/helpdesk/index.html> or 202-463-4713.

American Wood Council

Attachment 2.

Computing Tributary Deck Area for Sizing Footings

The size of the concrete piers that are required to support a deck is based on the square footage of deck being supported by that column and pier. This square footage can be determined by using the figure below as an example. A column and pier supports an area of deck that is half way to the next support in any direction. The ledger connection at the house is considered a support. In the figure below, the interior post supports half the joist span going back to the house and half the joist span going toward the outside edge of the deck. Since each set of joists span 8 feet, the post and pier supports 4 feet of the span in each direction. That means the interior post and pier is carrying a total of 8 feet parallel to the joists. Next the distance between the posts and piers parallel to the beam must be determined. The posts shown in the diagram below are set 10 feet apart. The interior post and pier supports 5 feet of deck in both directions for a total of 10 feet along the length of the beam.

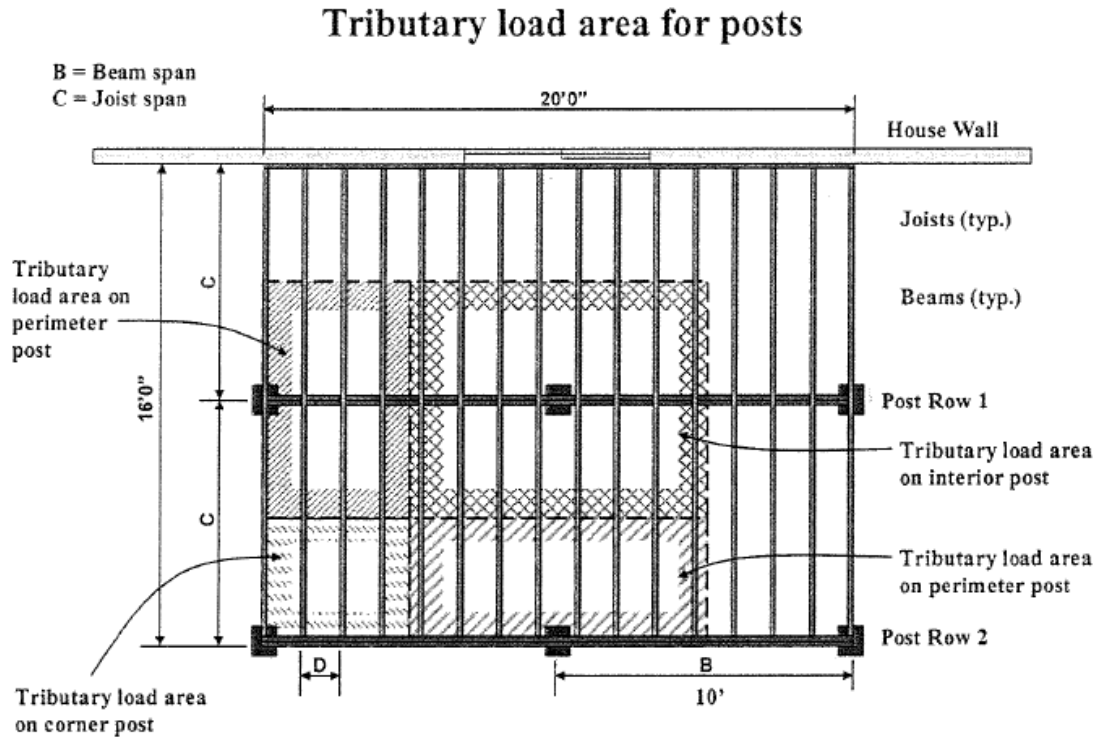

Plan View Not drawn to Scale

These two dimensions [8' times 10'] give an area of 80 square feet of deck supported by the interior post. The perimeter posts carry half the area of the interior post [4' times 10'] or 40 square feet, and the corner posts carry half the area of the perimeter posts, or 20 square feet. Now the size of the piers can be determined by using the Table below.

TRIBUTARY DECK AREA (SQ. FT.) - SEE ATTACHM'T 2	MIN. SQ. FTG. SIZE (FT. - IN.)	ALTERNATE ROUND PIER FTG. SIZE (IN)	REINF. EA. WAY BOTT.
16	1-0	12 *	-
24	1-3	16 *	-
48	1-6	18	2 - #4
72	1-9	24	2 - #4
96	2-0	27	2 - #4
120	2-3	30	3 - #4
144	2-6	33	3 - #4

*Reinforce round piers as shown on Page 4

Footing sizes may be chosen individually, based on the square footage of deck supported by each pier. That would mean each pier might require a different size footing. An easier way is to determine the largest size footing needed and make all of them the same size.

Attachment 3.

General Requirements for Covers Over Residential Wood Framed Decks

This attachment is intended to provide general direction for the user when constructing a residential wood framed deck with a wood framed roof covering above it. It assumes that the user is familiar with conventional roof framing techniques, building code requirements and that the roof covering is only to be used above a deck of a type outlined in the scoping paragraph on page 2 of this standard.

For situations and roof covers that are outside of the scoping provisions of this document the International Residential Code, as currently adopted by the City of Wichita, shall be considered the controlling document.

The roof covers may be constructed with field framed rafters and ceiling joists or with manufactured metal plate connected wood trusses. This standard further assumes that the roof cover will be open to the exterior without enclosing walls (insect screens and screen doors are permitted), have both a roof diaphragm and a ceiling diaphragm which is in plane with the bearing beams or headers (i.e....not a vaulted ceiling). Field framed rafters and ceiling joist spans shall be in accordance with the span tables published in the International Residential Code, as currently adopted by the City of Wichita. The bearing ends of each rafter or truss shall be connected to the top plates of walls or to beams or headers with manufactured metal plate connectors (i.e....hurricane straps).

Headers and beams shall be securely connected to the wall framing of the main house structure by means of manufactured beam hangers or by framing the ends of the beam(s) or header(s) into pockets as illustrated by Figure 1.

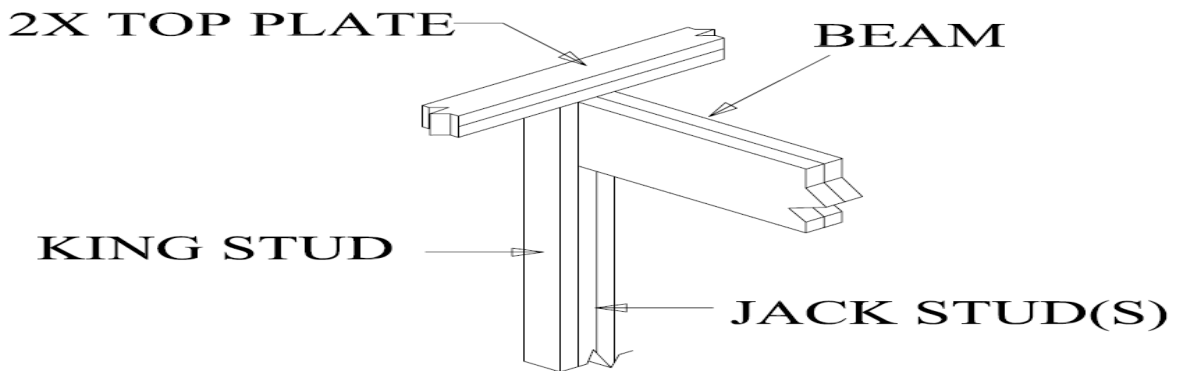

**BEAM POCKET FRAMED
INTO EXTERIOR STUD WALL
SIZE POCKET PER BEAM DIM'S**

FIG. 1

Beam(s) or header(s) must be positively secured to the tops of continuous min. 6 x 6 nominal posts at all bearing locations. See Fig. 3. This must be accomplished by using manufactured saddles, ties, or straps; or by the notching and bolting method shown in figure 4. The supporting beam(s) or header(s) may not simply be “sitting” on top of the posts and fastened with toe-nails or screws.

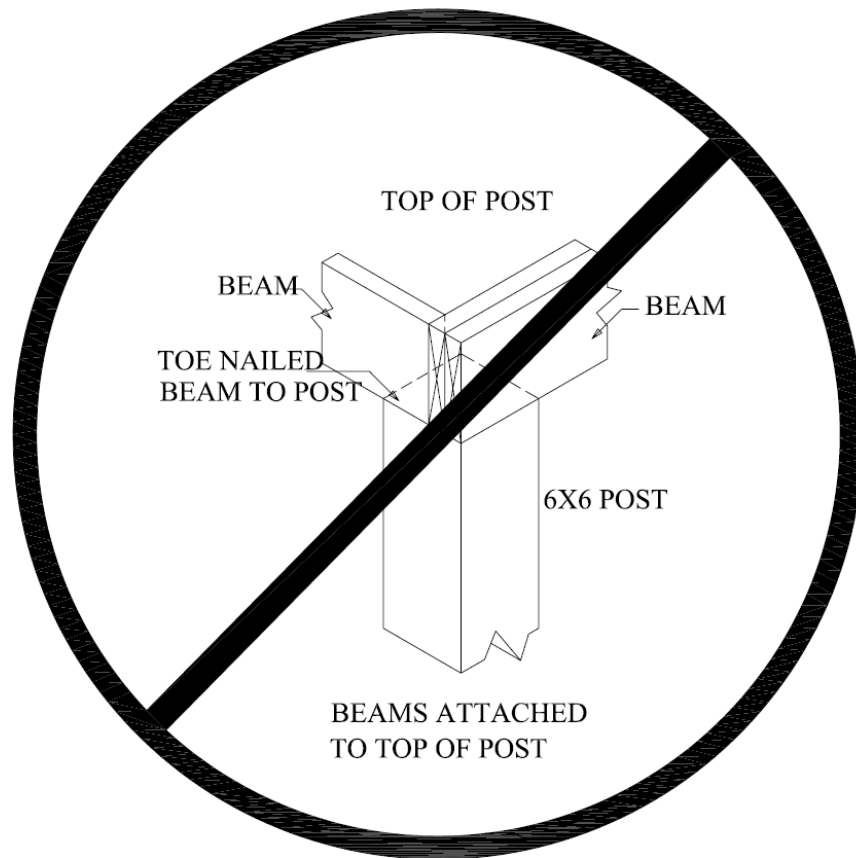
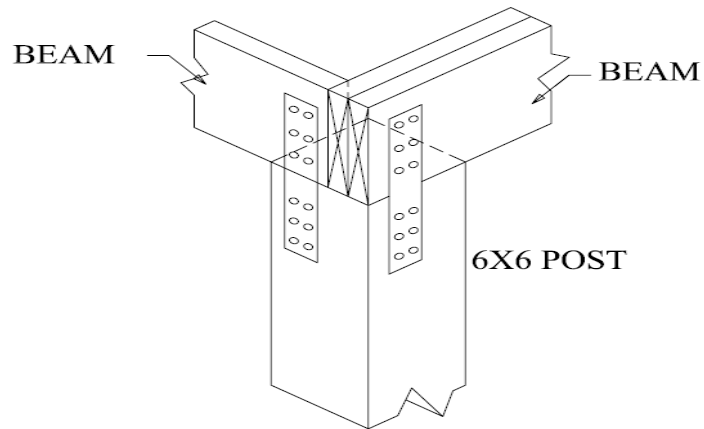
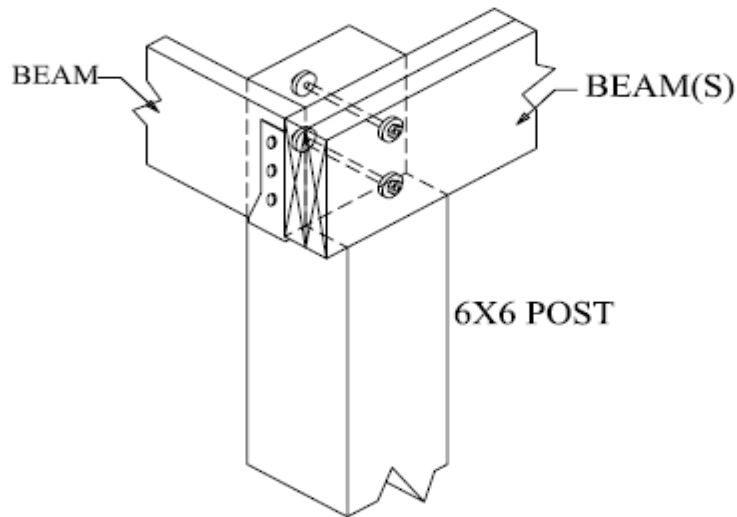

FIG. 2



BEAMS ATTACHED
TO TOP OF POST
W/ APPROVED
PRE-MFGRD PRODUCT

FIG. 3



NOTCHED POST
THRU BOLTED BEAMS
BEAM(S) CANTILEVERED PAST POST
SIDE BEAM ATTACHED
W/ APPROVED HANGER (INSIDE FLANGES)
SIMPSON HUSC OR EQUIVALENT

FIG. 4

The roof cover beams may also be designed as a “sistered” double beam by using the method shown in figures 5 and 6. This method is useful for the beams on the outside portion of the deck as well.

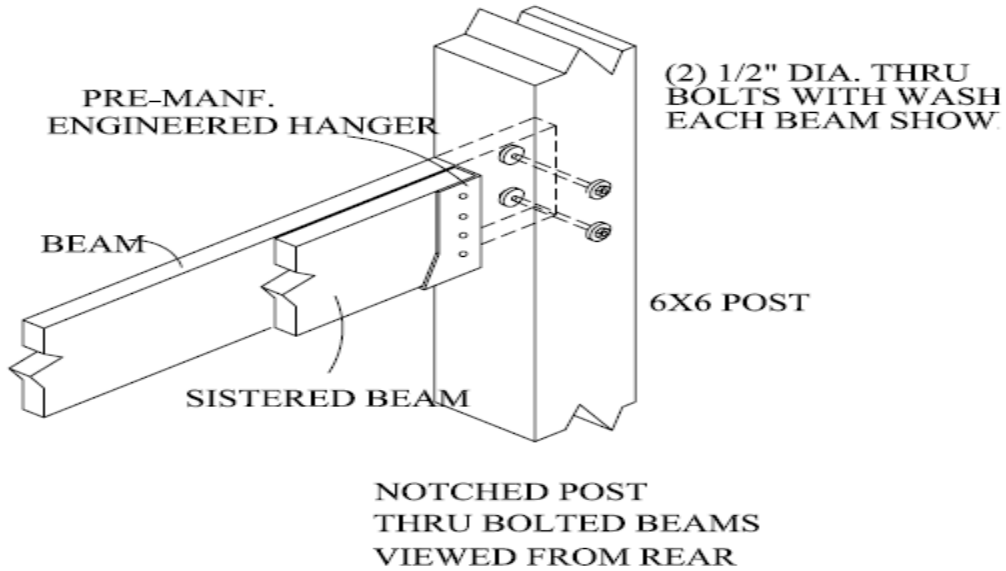

FIG. 5

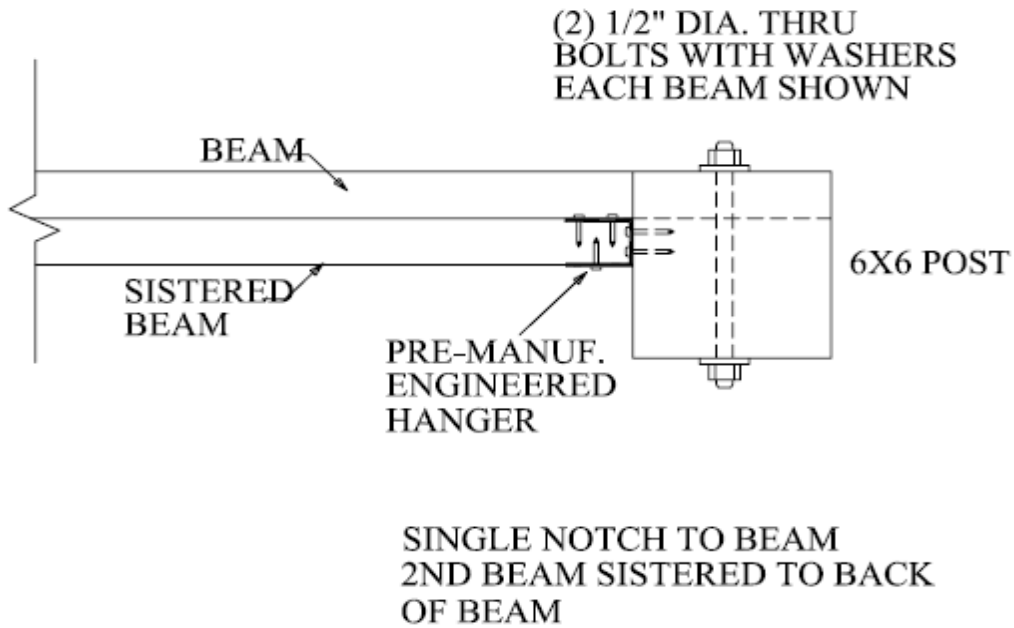

FIG. 6

When constructing the roof cover for the deck, the posts supporting the deck may also be used to support the roof load. They must be continuous posts from the foundation up to the roof beams. They must not have more than one 3 inch notch cut in one face at the deck level to support the deck beam(s) and one 3 inch notch cut in one face at the top of the post for the roof beam(s). The notches **MUST NOT BE OVERCUT!!** The beam(s) must fit snugly into the notches in order to avoid weakening the posts. If the tributary area of the roof is greater than the tributary area of the deck which is supported on the same post; the post foundation and footing size must be increased to be able to carry the larger of the areas or additional posts and foundations will be required.

The foundation design and tributary area for the posts is to be determined using **Attachment 2** of this document. If the area exceeds the limits of the table, the load should be distributed to additional posts and footings/foundations or designed and sealed by a licensed Kansas professional.

Figures 7 and 8 below, showing the side and front elevations of a typical deck with roof cover should help to clarify the provisions of this attachment.

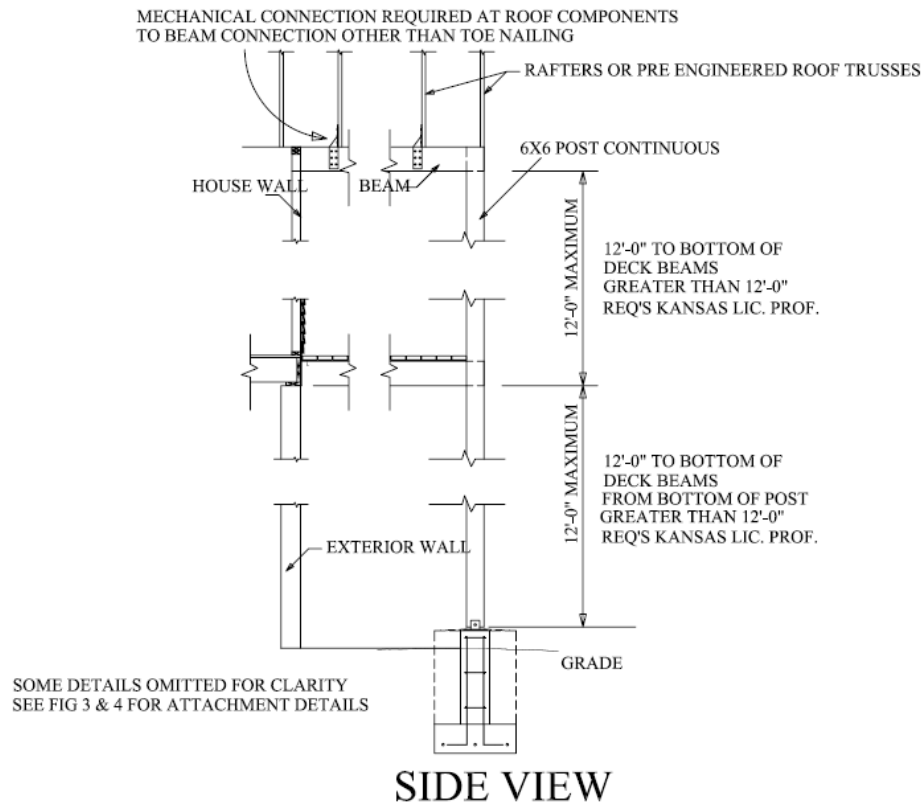

FIG. 7

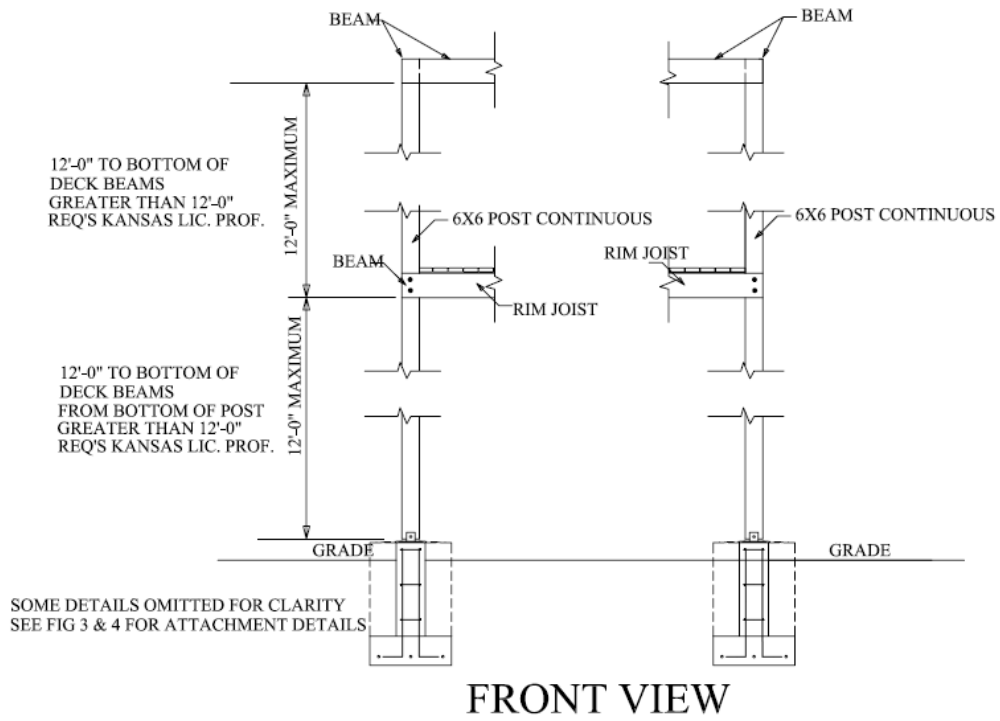

FIG. 8

Attachment 4.

Option for using 4 x 4--Deck only--Support Posts

It has been determined that for constructing decks without roof coverings, and which do not exceed six (6') feet from the bottom of the floor joists to the bottom of the support posts, that nominal 4" x 4" treated or naturally decay resistant posts may be substituted for the required 6" x 6" posts. The posts must remain un-notched and support beams must be supported at the ends with proper mechanical hangers or have a minimum of 1.5" of end bearing to foundation.

Deck posts may be supported by manufactured column and footing supports that have prior approval and inspection by the authority having jurisdiction. Footing supports must bear on undisturbed or properly compacted soil below the frost depth for the City of Wichita.

NOTE: The maximum tributary area of decks on 4" x 4" treated or naturally decay resistant lumber that are latterly unsupported and max. of 6 ft. posts shall not exceed 144 sq. feet.

The maximum tributary area of decks on 6" x 6" treated or naturally decay resistant lumber that are latterly unsupported and max. of 12 ft. posts shall not exceed 144 sq. feet.

Options for Post Spacing and Top Cap Rail Attachment of Guard Rail

Spacing for guard rail posts may be increased to a maximum of eight (8) feet on center when a nominal 2" x 6" top cap rail placed with the 6" face parallel to the horizontal deck surface is used and properly fastened to the supporting posts. The post spacing for use with a nominal 2" x 4" top cap rail placed with the 4" face parallel to the horizontal deck surface must not exceed six (6) feet on center.

The top cap rail may be attached to the top of the supporting posts by the following method. (See figure below)

